

AUTO-KLEAN® Model G Filter System



The Auto-Klean Model G is an all metal cleanable edge filter. The cast iron head is gasket sealed to the sump by a reinforcing ring and screws to allow sump removal without disturbing pipe connections. A vent screw and sump drain are provided to allow ease of maintenance and operation. An angle type mounting bracket attached to the filter head is also included. Auto-Klean Model GU is the same as the model G, but is listed by Underwriters' Laboratory (UL File MP 485) as suitable for service on oil burner fuel supply lines with operating parameters up to 90 psi and 77 gallons per hour. A motorized version Model MG is available. Consult your CUNO Representative for more information.

THEORY OF OPERATION

The Auto-Klean cartridge is an assembled unit composed of a stack of alternating metal discs and spacers of uniform thickness on a rotatable metal shaft. The thickness of the spacer determines the degree of filtration. Auto-Klean Model G is available in spacings from 0.003" to 0.015".

Cleaning blades are mounted on a stationary rod adjacent to the cartridge stack and extend into the openings between the discs. Turning the cartridge handle rotates the disc and spacer assembly past the fixed cleaner blades. By rotating the cartridge, in either direction, the particles lodged between the discs are positively removed or "combed" from the surface without interruption of flow. Drain the sump as often as experience indicates is necessary.

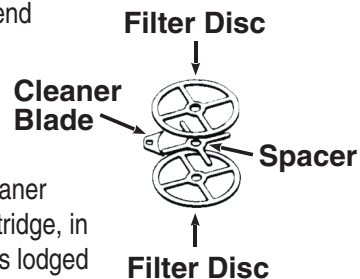

SPECIFICATIONS

Table 1 lists the Model G general specifications.

TABLE 1. - MODEL G GENERAL SPECIFICATIONS	
Inlet/Outlet Connection	3/4" NPT
Drain	1/2" NPT
Vent	1/8" NPT
Max. Operating Pressure	125 psi @ 200°F
Sludge Capacity	2.4 in ³
Shipping Weight	5 lbs
HOUSING DATA	
Head	Cast Iron
Sump	Drawn Steel
Head Gasket	Buna N/Cork
Gland Packing	PTFE-Aramid Fiber
CARTRIDGE DATA	
Diameter	1 1/4"
Length	4 1/2"
Material *	Steel, Brass, or 304 SS
Spacing	0.003", 0.005", 0.008", 0.012" or 0.015"

* Check catalog numbers for available combinations of material and spacing

FEATURE	BENEFIT
<ul style="list-style-type: none"> Cleanable design 	<ul style="list-style-type: none"> Eliminates used filter cartridge disposal
<ul style="list-style-type: none"> Positive cleaning action with no interruption of flow or service 	<ul style="list-style-type: none"> Maximizes process up-time
<ul style="list-style-type: none"> Rugged all metal construction for trouble-free operation 	<ul style="list-style-type: none"> Can handle highly viscous fluids Economical solution to long term filtration needs

FLOW CAPACITY

The flow rates listed in Table 2 are based on clean fluid with a pressure drop of 3 psi. Flow rates for other viscosity fluids are approximately proportional. Select a filter model according to the nature and concentration of the contaminant to be removed.

TABLE 2. - MODEL G FLOW RATES						
SPACING(IN.)	SCREEN MESH EQUIV.	FREE AREA (in ²)	VISCOSITY IN SSU			
			100	300	700	2000
			FLOW IN GPM			
0.003	200	3.0	5.0	3.1	1.8	1.0
0.005	120	4.0	6.0	3.9	2.4	1.4
0.008	70	5.4	6.6	4.6	2.7	1.7
0.012	50	6.9	7.3	5.2	3.2	1.9
0.015	40	7.7	7.5	5.5	3.3	2.0

CATALOG NUMBERS

MODEL	SPACING (in.)	FILTER CATALOG NUMBER	CARTRIDGE CATALOG NUMBER
G	Steel Cartridge		
	0.003	13018-26-50-0030	13131-07-50-0030
	0.005	13018-26-50-0050	13131-07-50-0050
	0.008	13018-26-50-0080	13131-07-50-0080
	0.012	13018-26-50-0120	13131-07-50-0120
	0.015	13018-26-50-0150	13131-07-50-0150
	Brass Cartridge		
	0.003	13018-26-20-0030	13131-07-20-0030
	0.005	13018-26-20-0050	13131-07-20-0050
	0.012	13018-26-20-0120	13131-07-20-0120
	Stainless Steel Cartridge		
	0.003	13018-26-40-0030	13131-07-40-0030
	0.005	13018-26-40-0050	13131-07-40-0050
	0.008	13018-26-40-0080	13131-07-40-0080
	0.012	13018-26-40-0120	13131-07-40-0120
0.015	13018-26-40-0150	13131-07-40-0150	

For replacement parts, contact your CUNO Representative.

DIMENSIONS

Rough plumbing dimensions for the Model G are given in Figure 1.

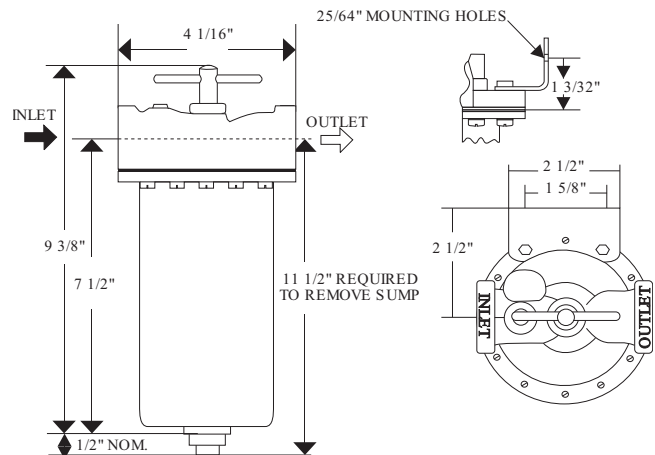

Important Notice

CUNO MAKES NO WARRANTIES, EXPRESS OR IMPLIED, INCLUDING, BUT NOT LIMITED TO, ANY IMPLIED WARRANTY OF MERCHANTABILITY OR FITNESS FOR A PARTICULAR PURPOSE. Since a variety of factors can affect the use and performance of a CUNO product in a particular application, some of which are uniquely within the user's knowledge and control, user is responsible for determining whether or not the CUNO product is fit for a particular purpose and suitable for user's method of application.

Limitation of Remedies and Liability

If the CUNO product is proved to be defective, THE EXCLUSIVE REMEDY, AT CUNO'S OPTION, SHALL BE TO REFUND THE PURCHASE PRICE OR TO REPAIR OR REPLACE THE DEFECTIVE PRODUCT. CUNO shall not otherwise be liable for loss or damages, whether direct, indirect, special, incidental or consequential, regardless of the legal theory asserted, including, but not limited to, contract, negligence, warranty or strict liability.

WARRANTY

Seller warrants its equipment against defects in workmanship and material for a period of 12 months from date of shipment from the factory under normal use and service and otherwise when such equipment is used in accordance with instructions furnished by Seller and for purposes disclosed in writing at the time of purchase, if any. Any unauthorized alteration or modification of the equipment by Buyer will void this warranty. Seller's liability under this warranty shall be limited to the replacement or repair, F.O.B. point of manufacture, of any defective equipment or part which, having been returned to the factory, transportation charges prepaid, has been inspected and determined by the Seller to be defective. THIS WARRANTY IS IN LIEU OF ANY OTHER WARRANTY, EITHER EXPRESSED OR IMPLIED, AS TO DESCRIPTION, QUALITY, MERCHANTABILITY, FITNESS FOR ANY PARTICULAR PURPOSE OR USE, OR ANY OTHER MATTER. Under no circumstances shall Seller be liable to Buyer or any third party for any loss of profits or other direct or indirect costs, expenses, losses or consequential damages arising out of or as a result of any defects in or failure of its products or any part or parts thereof or arising out of or as a result of parts or components incorporated in Seller's equipment but not supplied by the Seller.



a 3M company

CUNO Incorporated

400 Research Parkway
Meriden, CT 06450, U.S.A.

Tel: (800) 243-6894

(203) 237-5541

Fax: (203) 630-4530

www.cuno.com