

NanoSHIELD[®] MDC

Filter Capsules

Superior Defect Reduction from Advanced Photoresists and Chemicals

NanoSHIELD MDC filter capsules have been specially designed to reduce wafer level defects from advanced photoresist and ancillary chemical applications. Utilizing Hollow Fiber Technology (HFT), NanoSHIELD filters are able to deliver superior flow with minimal pressure drop, while maintaining the highest level of filter efficiency in a compact design.

The small compact design of NanoSHIELD MDC filter capsules make them ideally suited for applications requiring low hold-up volume with superior flow rates and high particle retention at 0.01, 0.02, 0.05, and 0.1 μm .

NanoSHIELD Capsule Construction

Manufactured in a clean room environment from polypropylene and polyethylene materials, NanoSHIELD capsules will not contribute to ionic, organic, and metallic contaminant levels in the process fluid. Ionic, organic, and metallic contaminants can extract from surface modified and or improperly manufactured filters, which may reduce shelf life, or change the photo-speed and molecular weight of the photo-chemical. NanoSHIELD MDC capsules are critically cleaned, integrity tested, and rinsed with 18 megohm DI water to minimize extractables and allow process repeatability out of the box.

Features & Benefits

Hollow Fiber Technology.

- More surface area as compared to equivalent sized capsules.
- Provides both lower operating and differential pressure across the filter to minimize outgassing and micro-bubble formation.
- Increased lifetime, throughput, and overall equipment effectiveness (OEE).

Polypropylene and Polyethylene Construction.

- Excellent chemical resistance to ARC's, photoresists and solvents.
- No pre-wetting required for solvent based chemicals.

0.01 μm and 0.02 μm Retention Ratings.

- Superior removal of particles, gels, and micro-bubbles.
- Reduced micro-bridge and wafer level defects for 193 nm photoresists.

Superior Flow Rates.

- Flow rates 3 - 5 times higher as compared to equivalent size competitive pleated capsules while not sacrificing particle removal efficiency.

Quality Manufacturing.

- All filters are critically cleaned and tested in a cleanroom to reduce particle adders and extractables.



Applications

193 nm Photoresists	Alcohols
---------------------	----------

ARC, BARC, TARC	Bases
-----------------	-------

Etchants/ Strippers	Developers
---------------------	------------

Polyimide	Solvents
-----------	----------

Graph 1: Typical 1 cps Flow vs. Differential Pressure @ 25°C

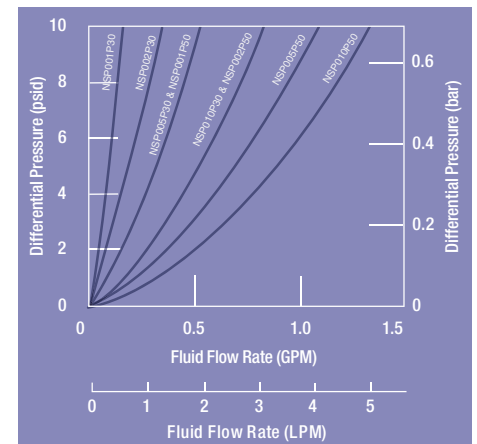

NanoSHIELD® MDC Filter Capsules

NanoSHIELD MDC Filter Capsules Specifications

Membrane Material	Hollow Fiber Polypropylene
Capsule Body	Polyethylene
Potting Material	Polyethylene
Filtration Surface Area	5" MDC – 4.1 ft ² (3800 cm ²) 3" MDC – 1.8 ft ² (1700 cm ²)
Maximum Operating Pressure	58 psig @ 77°F (4 bar @ 25°C)
Maximum Operating Temperature	104°F (40°C)
Absolute Removal Ratings (µm)	0.01, 0.02, 0.05, and 0.1
Maximum Differential Pressure	28 psid @ 77°F (1.9 bar @ 25°C)
Filter Capsule Integrity	100% Tested

Dimensions

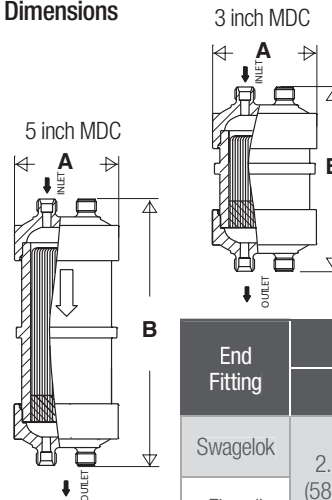

End Fitting	5" MDC		3" MDC	
	A	B	A	B
Swagelok	2.28" (58 mm)	5.81" (147.6 mm)	2.28" (58 mm)	3.88" (98.5 mm)
Flowell		7.08" (180 mm)		5.15" (130.8 mm)

Ordering Guide

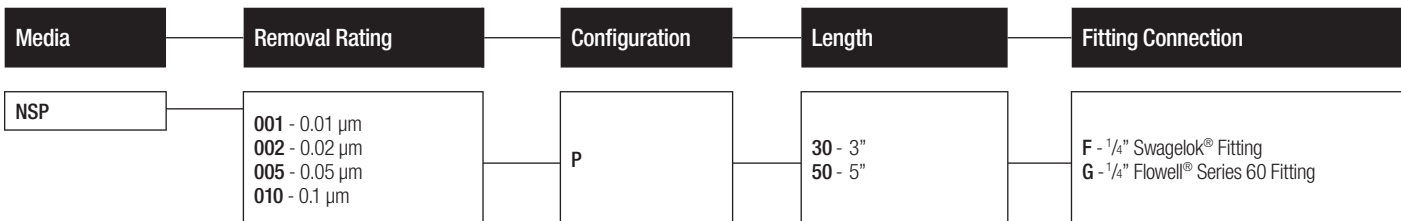

Example – A 0.02 micron MDC capsule with 1/4" Swagelok fittings would be NSP002P50F.
Consult factory for pre-wet capsules.

Important Notice

CUNO MAKES NO WARRANTIES, EXPRESS OR IMPLIED, INCLUDING, BUT NOT LIMITED TO, ANY IMPLIED WARRANTY OF MERCHANTABILITY OR FITNESS FOR A PARTICULAR PURPOSE. Since a variety of factors can affect the use and performance of a CUNO product in a particular application, some of which are uniquely within the user's knowledge and control, user is responsible for determining whether or not the CUNO product is fit for a particular purpose and suitable for user's method of application.

Limitation of Remedies and Liability

If the CUNO product is proved to be defective, THE EXCLUSIVE REMEDY, AT CUNO'S OPTION, SHALL BE TO REFUND THE PURCHASE PRICE OR TO REPAIR OR REPLACE THE DEFECTIVE PRODUCT. CUNO shall not otherwise be liable for loss or damages, whether direct, indirect, special, incidental or consequential, regardless of the legal theory asserted, including, but not limited to, contract, negligence, warranty or strict liability.

Warranty

Seller warrants its equipment against defects in workmanship and material for a period of 12 months from date of shipment from the factory under normal use and service and otherwise when such equipment is used in accordance with instructions furnished by Seller and for purposes disclosed in writing at the time of purchase, if any. Any unauthorized alteration or modification of the equipment by Buyer will void this warranty. Seller's liability under this warranty shall be limited to the replacement or repair, F.O.B., point of manufacture, of any defective equipment or part which, having been returned to the factory, transportation charges prepaid, has been inspected and determined by Seller to be defective. THIS WARRANTY IS IN LIEU OF ANY OTHER WARRANTY, EITHER EXPRESSED OR IMPLIED, AS TO DESCRIPTION, QUALITY, MERCHANTABILITY, FITNESS FOR ANY PARTICULAR PURPOSE OR USE, OR ANY OTHER MATTER. Under no circumstances shall Seller be liable to Buyer or any third party for any loss of profits or other direct or indirect costs, expenses, losses or consequential damages arising out of or as a result of any defects in or failure of its products or any part or parts thereof or arising out of or as a result of parts or components incorporated in Seller's equipment but not supplied by the Seller.



a 3M company

CUNO Incorporated

400 Research Parkway
Meriden, CT 06450
U.S.A.
(800) 243-6894
(203) 237-5541
Fax (230) 630-4530
www.CUNO.com

CUNO and NanoSHIELD are trademarks of 3M Company used under license. 3M is a trademark of 3M Company. Swagelok is a trademark of Swagelok Company. Flowell is a trademark of Flowell Corporation.

© 2008 3M Company. All rights reserved.
70-0201-8780-6
LITNSHLDMDC1.1208

Your Local CUNO Distributor: