

3M Purification Inc.

Zeta Plus™ Encapsulated System



Innovative
Filtration

Fast. Easy. Clean.





Zeta Plus™ Encapsulated System... The System of Choice for Disposable Depth Filtration

Features & Benefits

Ergonomically Designed Holder System:

Large holder (Model# 16EZB) can be pivoted between horizontal and vertical positions.

- Enables loading and unloading at waist height.
- Minimal fluid spills when handling spent capsules.
- Single or two-stage depth filtration within one filter holder.

Vertical flow path.

- Full utilization of the filter media.
- Small footprint during filtration.

Innovative Capsule/Manifold Design:

Translucent plastic shell (Standard Capsules).

- Easy detection of the liquid level inside, providing real time monitoring of the filtration process.

Solid core design with fully encapsulated shell.

- Eliminates the need for a stainless steel housing and the cleaning step after filtration.
- Low hold-up volume.

Self guiding locking mechanism.

- Fast, reliable and robust capsule-to-capsule connectivity.

Lenticular style capsule design.

- Linear scalability from small to large system.
- Consistency between disposable and conventional depth filtration.

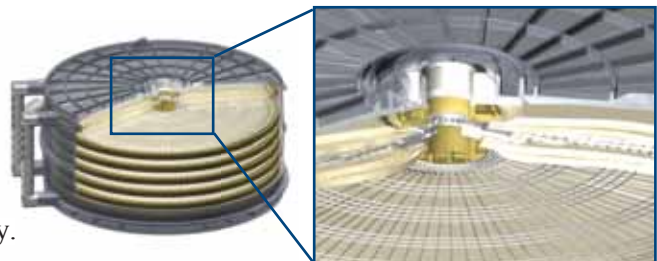

Zeta Plus™ EXT Series Filter Media:

- Broad range of filter media selection.
- Superior performance in throughput and filtration efficiency.



Zeta Plus™ Encapsulated Standard Capsule Offering With Polycarbonate Shells

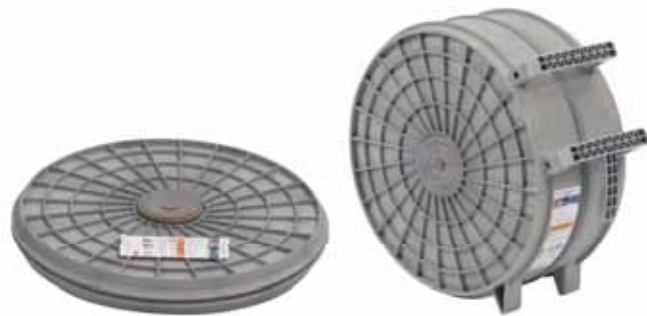

Zeta Plus™ Encapsulated Capsule Offering With Alkaline Resistant* Polyphenylene / Polystyrene Shells



Standard Zeta Plus™ Cartridges and BC Capsule

The Zeta Plus™ Encapsulated System is a disposable depth filtration system designed for the bioprocessing industry where upstream cell culture clarification or downstream impurity removal is required. The Zeta Plus Encapsulated System consists of two product lines: a small system that is ideal for lab scale production or scale up studies, and a large system that is designed for production scale biomanufacturing. Each system is comprised of a filter holder, a set of top and bottom manifolds, and a flexible number of capsules.

The Zeta Plus Encapsulated System features an ergonomically designed large holder (Model# 16EZB) that can be pivoted between horizontal and vertical positions, allowing convenient loading and unloading, minimal footprint during filtration, minimal fluid spills during unloading, and full utilization of the filter media.

The capsule design offers a translucent plastic shell (standard capsules) for easy liquid level detection; a self guiding locking mechanism for fast and robust capsule-to-capsule connection; and the industry leading Zeta Plus™ EXT Series filter media used in our cartridges that provides superior filtration performance.



Self Guiding Locking Mechanism Enables Fast And Robust Capsule-To-Capsule Connection

* Based on testing with 1M NaOH and 5% NaClO (Bleach). See Chemical Compatibility Guide (70-0202-2023-5/LITPHG03) for more information.



High Performance Filter Media

The Zeta Plus™ Encapsulated System utilizes the industry leading Zeta Plus™ EXT Series filter media. The Zeta Plus EXT Series is a family of advanced dual zone depth filters designed to provide optimal clarification of bioprocess and biological fluids. Most Zeta Plus EXT Series filters consist of two distinct layers, or “zones” of filter media with the upstream zone more open than the downstream one. This structure enhances the contaminant holding capacity of the filter media, reduces premature plugging and helps extend service life. All Zeta Plus EXT media grades are available including a special grade (DELI08A) that is designed for lipid removal.

Applications

- Clarification of mammalian cell culture harvest.
- Enhanced protection of downstream processes.
- Clarification of bacteria, yeast and insect cell lysates.
- Host Cell Proteins (HCP) removal.
- Viruses and DNA reduction.
- Protein aggregates removal.
- Endotoxin removal.
- Anti-foaming agents removal.



The primary application for the Zeta Plus Encapsulated System is the cell culture clarification after fermentation. The System can be employed alone, or in combination with centrifugation or Tangential Flow Filtration (TFF). An alternative application for the Zeta Plus Encapsulated System is downstream impurity removal. Taking advantage of its positive charge capacity, Zeta Plus EXT Series filter media has been shown to be effective in removing contaminants such as host cell proteins (HCP), viruses, DNA, protein aggregates, and endotoxins.

In monoclonal antibody production, Zeta Plus EXT Series media is increasingly being used as a polishing step after Protein A column, replacing traditional anion exchange chromatography.

Table 1. Recommended Operating Parameters

	Small System (Model# 16EZA)	Large System (Model# 16EZB)
Maximum Operating Pressure		
Inlet Pressure	50 psi (3.4 bar)	50 psi (3.4 bar)
Differential Pressure	35 psi (2.4 bar)	35 psi (2.4 bar)
Maximum Operating Temperature	104°F (40°C)	104°F (40°C)
Recommended Pre-use Rinse	54 L/m ²	54 L/m ²
Recommended Flux	50 - 150 LMH	50 - 150 LMH

Figure 1. Zeta Plus™ Encapsulated Large Holder Loading Process



Ergonomically Designed Filter Holders

Large Holder (Model# 16EZB)

Traditional depth filtration systems utilize lenticular style cartridge filters and a vertical filtration flow path to allow easy access to process liquids and efficient utilization of filter media. However, stacking cartridges from bottom to top can be cumbersome and dismantling spent cartridges is often labor intensive. Furthermore, fluid spills during the unloading process could be problematic and, in some instances, might expose the operators to the process fluids.

Recognizing the need for a depth filtration system that is fast, easy and clean, 3M Purification Inc. designed a filter holder (Model# 16EZB) that can be pivoted between the horizontal position for loading and unloading, and the vertical position for filtration. Allowing loading and unloading at waist height eliminates the need for operators to lift capsules above their heads and reduces the risk of fluid spills when handling spent capsules. The use of the vertical flow path helps ensure full media utilization and a small system footprint during filtration. The large holder can accommodate up to 11.2 m² of filter media, and is ideal for production scale purification processes. The large holder is designed to perform either single-stage or two-stage depth filtration within the same holder. Holder components are non-wetted parts, eliminating the need for cleaning-in-place (CIP) and the associated cleaning validation after each filtration run.

Small Holder (Model# 16EZA)

A small holder is available for scale up studies and lab scale protein production. This holder can accommodate from one to four 0.23 m² capsules, or one 1.6 m² capsule. Either single stage or two-stage depth filtration can be performed within the same holder. The standard small holder has a built-in torque limiter that will signal the operator when the holder assembly is properly sealed. A modified version is available that is ideal for applications where autoclaving is required.

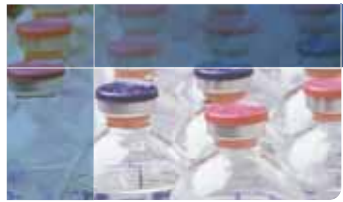

Innovative Capsule/Manifold Design

Two capsule configurations are available for use with the Zeta Plus™ Encapsulated System. The 0.23 m² capsule is designed for use with the small holder in lab scale production and scale up studies. The 1.6 m² capsule is designed for use with both the small and large holders. The 1.6 m² capsule has a self guiding locking mechanism for a fast, easy, and robust capsule-to-capsule connection, and a solid core design that eliminates the need for stainless steel bands and center post. In addition, this capsule also has two handles for convenient loading and unloading, and a low capsule fill volume and post-blown down hold-up volume. The capsule plastic shells are available in two different materials for a broad range of applications. The standard capsules use polycarbonate, thus have the translucent plastic shells that enables easy liquid level detection. The alkaline resistant* capsules use polyphenylene/polystyrene, and can be used in applications where NaOH is required either before or after filtration. Correspondingly, the single use top and bottom manifolds are also available in these two materials. The manifold set ensures the entire filtration process is fast, easy, and clean. An extra pair of manifolds is required to perform two-stage filtration within one holder assembly.

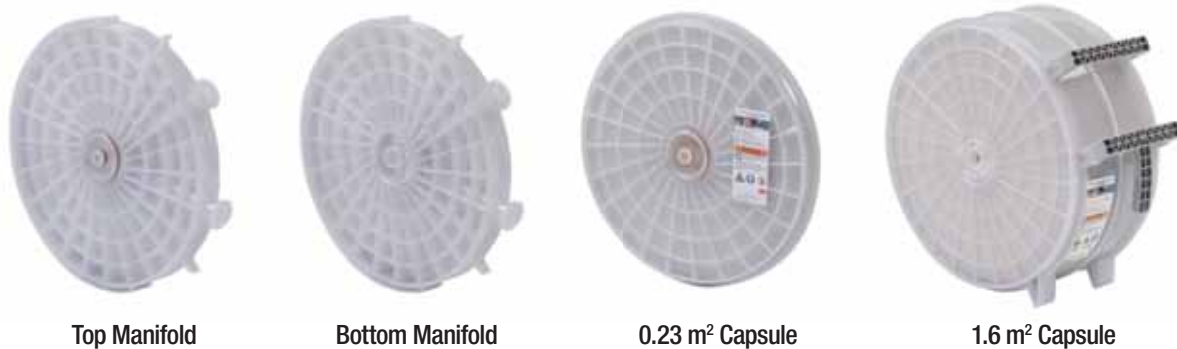
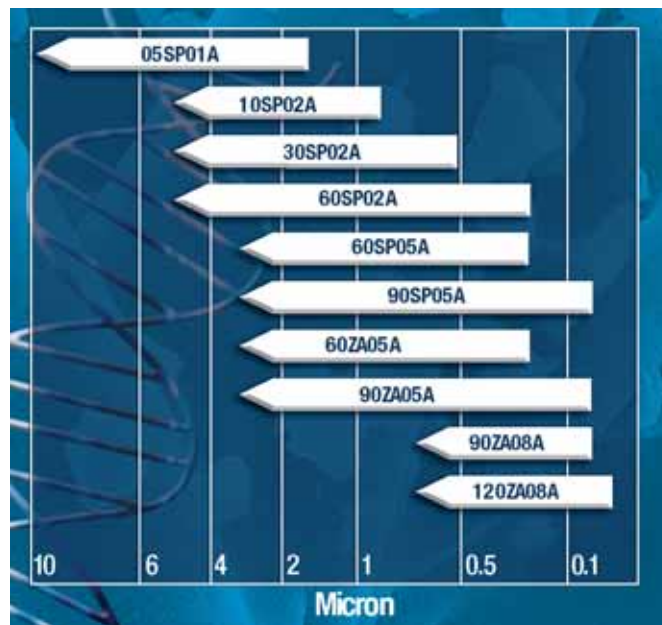

Figure 2. Nominal Retention Ratings for Zeta Plus™ EXT Grades
(For reference only. Retention ratings may vary depending on use applications.)



* Based on testing with 1M NaOH and 5% NaClO (Bleach).
See Chemical Compatibility Guide (70-0202-2023-5/LITPHG03) for more information.

Table 2. Zeta Plus™ Encapsulated System Capsule Filter and Manifold Specifications

	Configuration			
	0.23 m ² Capsule		1.6 m ² Capsule	
	Standard	Alkaline Resistant ¹	Standard	Alkaline Resistant ¹
Dimensions (Height x Diameter)	2.2" x 17.8" (5.7 cm x 45.2 cm)		8.0" x 17.8" (20.3 cm x 45.2 cm)	
Weight				
Dry	7 lbs (3.3 kg)	8 lbs (3.4 kg)	22 lbs (10.0 kg)	24 lbs (10.7 kg)
Wet (post blown-down)	10 lbs (4.4 kg)	11 lbs (4.8 kg)	43 lbs (19.3 kg)	43 lbs (19.7 kg)
Materials of Construction				
Filter Media	Filter aids, cellulose, binding resin		Filter aids, cellulose, binding resin	
Outer Shell	Polycarbonate	Polyphenylene / Polystyrene	Polycarbonate	Polyphenylene / Polystyrene
O-rings	Silicone		Silicone	
Separators, Spacers and Connectors	Polypropylene		Polypropylene	
Edge Seals	Thermoplastic Elastomer		Thermoplastic Elastomer	
Handles	N/A		Nylon	
Hold-up Volume				
Capsule Fill Volume ²	~ 1.1 L		~ 5.2 L	
Post Blown-down Hold-up Volume ³	< 100 mL		< 100 mL	
Maximum Operating Line Pressure	50 psi (3.4 bar)		50 psi (3.4 bar)	
Maximum Differential Pressure				
Forward	35 psi (2.4 bar)		35 psi (2.4 bar)	
Sterilization	1 cycle autoclave (30 mins) at 126° C (259° F)		1 cycle autoclave (30 mins) at 126° C (259° F)	
Effective Filtration Area	2.4 ft ² (0.23 m ²)		17.1 ft ² (1.6 m ²)	
Top/Bottom Manifold				
Dimensions (Height x Diameter)	2.0" x 17.8" (5.2 cm x 45.2 cm)		2.0" x 17.8" (5.2 cm x 45.2 cm)	
Connector	1.5" Sanitary Style		1.5" Sanitary Style	
Material	Polycarbonate	Polyphenylene / Polystyrene	Polycarbonate	Polyphenylene / Polystyrene
Weight	10 lbs (4.3 kg)	10 lbs (4.7 kg)	10 lbs (4.3 kg)	10 lbs (4.7 kg)
Hold up volume	< 250 mL		< 250 mL	

¹ Based on testing with 1M NaOH and 5% NaClO (Bleach). See Chemical Compatibility Guide (70-0202-2023-5/LITPHG03) for more information.

² Capsule Fill Volume is defined as the volume of liquid that is required to fill the portion of the capsule outside the filter media.

³ Post Blown-down Hold-up Volume is defined as the volume of the residual liquid after nitrogen gas blown down.

Figure 3. Disposable Manifolds and Capsule Filter Diagrams

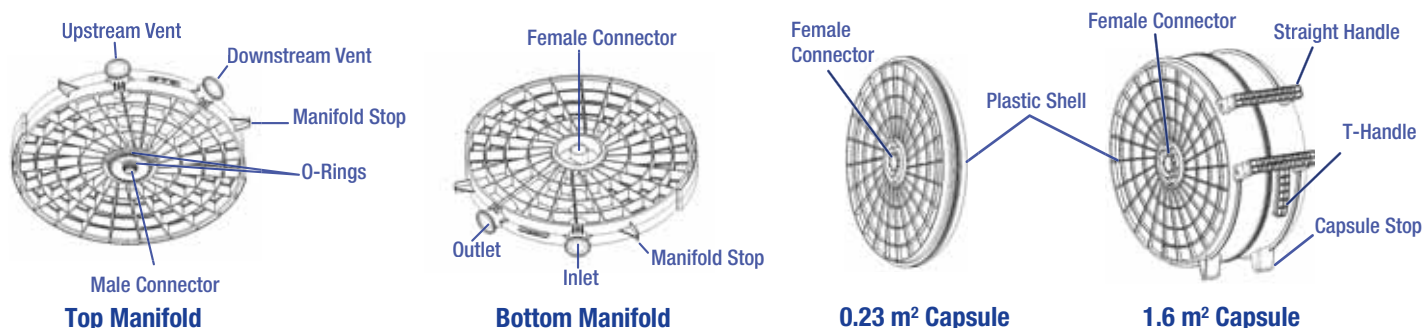

Figure 4. Disposable Zeta Plus™ Scale Up Devices



Scalability

The Zeta Plus™ Encapsulated System retains the lenticular filter design and vertical flow path that are characteristics of traditional depth filtration systems, helping ensure consistent performance from bench scale to production scale, and from disposable systems to traditional non-disposable systems.

Together with two disposable scale up devices — the BC25 capsule with 25 cm² filter media, and the BCE03 capsule with 0.1 m² filter media, the Zeta Plus Encapsulated System offers a completely disposable solution to process from 0.5 L to 2500 + L of liquid.





Table 3. Zeta Plus™ Encapsulated System Holder Specifications

	Holder Model	
	Small Holder (Model# 16EZA)	Large Holder (Model# 16EZB)
Maximum Operating Pressure	50 psi (3.4 bar)	50 psi (3.4 bar)
Materials of Construction		
Frame	304 Stainless Steel	304 Stainless Steel
End Plates	304 Stainless Steel	304 Stainless Steel
Support Rods	440 Stainless Steel	316 Stainless Steel
Stand	304 Stainless Steel	304 Stainless Steel
Hand Wheels	300 Series Stainless Steel	300 Series Stainless Steel
Gear Box	N/A	Epoxy Coated Cast Iron Cover
Locking Bar	N/A	304 Stainless Steel
Casters	Stainless Steel	Stainless Steel
Wheels	Phenolic	Polyurethane
Surface Finish		
Standard	Satin Glass Bead Finish (4814901 and 4815501)	Satin Glass Bead Finish (6123501)
Special	Electropolish Finish (4814902)	Mechanical Polish Finish (6123502)

Figure 6. Small Holder (Model# 16EZA) Dimensions

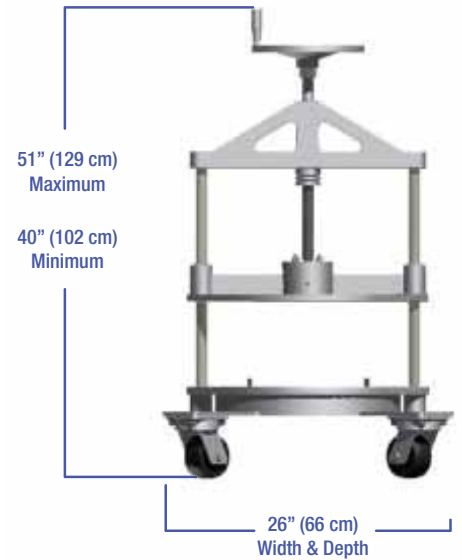
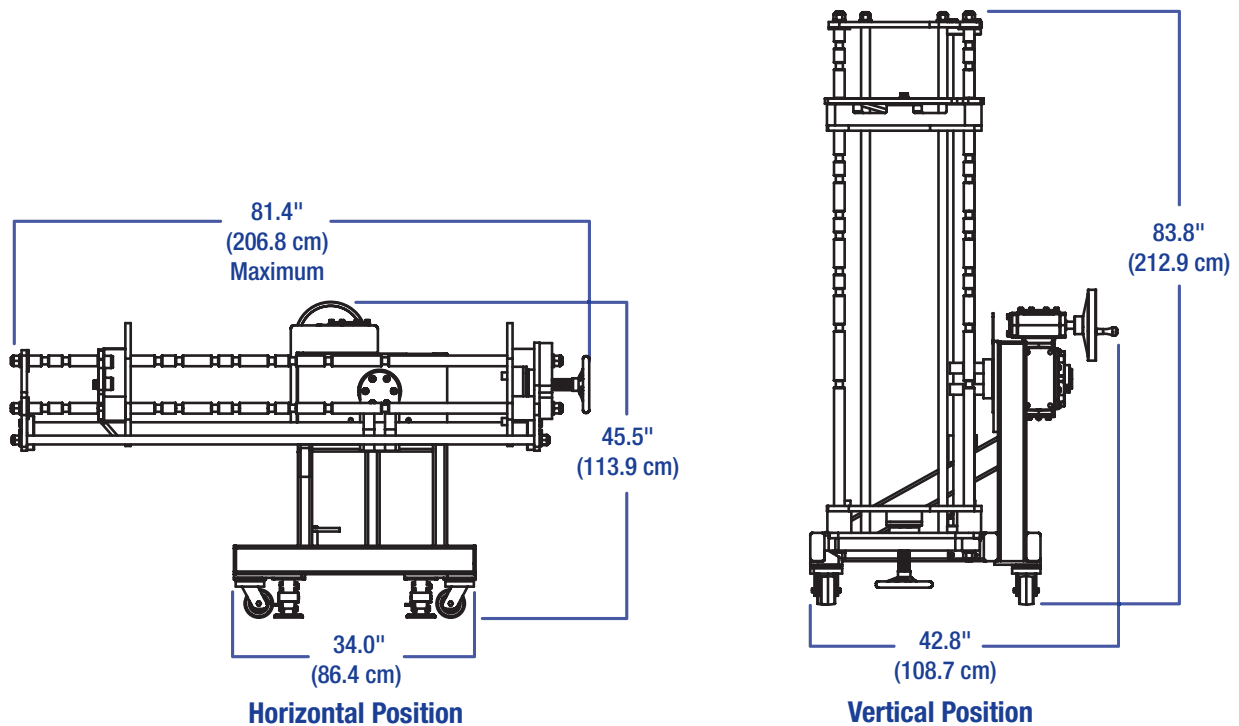

Table 4. Zeta Plus™ Encapsulated System Holder Capacity

Model	Single Stage		Two Stage	
	0.23 m ² Capsule	1.6 m ² Capsule	0.23 m ² Capsule	1.6 m ² Capsule
16EZA	4	1	2	NA
16EZB	NA	7	NA	6

Figure 7. Large Holder (Model# 16EZB) Dimensions



Zeta Plus™ Encapsulated System Ordering Guide

A-1. Capsule Filter Ordering Information (U.S. Customers)

Catalog Number	Configuration	Number of Cells	Gasket Material	Grade
E16	E - Standard R - Alkaline Resistant*	01 - 1 Cell	A - Silicone	05SP01A
		07 - 7 Cell		10SP02A 30SP02A 60SP02A 60SP05A 90SP05A 60ZA05A 90ZA05A 90ZA08A 120ZA08A DELI08A

NOTES:

- All Zeta Plus™ EXT media grades are available for order.
- For further information regarding Zeta Plus EXT Series filter media, please reference 3M Purification Literature 70-0201-8862-2 (LITZPMEXT) or 70-0201-8863-0 (LITZPMEXTSP1) and Chemical Compatibility Guide 70-0202-2023-5 (LITPHG03)
- DELI08A is a Zeta Plus EXT grade with two single layers of Delipid (DELI) media.

A-2. Standard Capsule Filter 3M ID Numbers for International Customers

3M PI ID (U.S. Customers)	3M ID (International Customers)	3M PI ID (U.S. Customers)	3M ID (International Customers)
E16E01A05SP01A	70020239011	E16E07A05SP01A	70020236918
E16E01A10SP02A	70020239029	E16E07A10SP02A	70020236561
E16E01A30SP02A	70020238534	E16E07A30SP02A	70020236942
E16E01A60SP02A	70020239078	E16E07A60SP02A	70020236603
E16E01A60SP05A	70020239094	E16E07A60SP05A	70020236959
E16E01A90SP05A	70020239102	E16E07A90SP05A	70020236629
E16E01A60ZA05A	70020238542	E16E07A60ZA05A	70020236967
E16E01A90ZA05A	70020239128	E16E07A90ZA05A	70020236975
E16E01A90ZA08A	70020238559	E16E07A90ZA08A	70020236983
E16E01A120ZA08A	70020238526	E16E07A120ZA08A	70020236926

A-3. Alkaline Resistant* Capsule Filter 3M ID Numbers for International Customers

3M PI ID (U.S. Customers)	3M ID (International Customers)	3M PI ID (U.S. Customers)	3M ID (International Customers)
E16R07A05SP01A	70020262740	E16R01A05SP01A	70020262609
E16R07A10SP02A	70020262757	E16R01A10SP02A	70020262625
E16R07A30SP02A	70020262799	E16R01A30SP02A	70020262948
E16R07A60SP02A	70020262823	E16R01A60SP02A	70020262682
E16R07A60SP05A	70020262849	E16R01A60SP05A	70020262955
E16R07A90SP05A	70020262864	E16R01A90SP05A	70020262716
E16R07A60ZA05A	70020262856	E16R01A60ZA05A	70020262708
E16R07A90ZA05A	70020262880	E16R01A90ZA05A	70020262963
E16R07A90ZA08A	70020262898	E16R01A90ZA08A	70020262732
E16R07A120ZA08A	70020262773	E16R01A120ZA08A	70020262641

B. Manifold Ordering Information

Manifold Part	3M PI Part Number	3M ID
Manifold Set (Standard)	6128901	70020256221
Manifold Set (Alkaline Resistant*)	6129001	70020262369

C. Filter Holder Ordering Information

Model Name	3M PI Part Number	Description	3M ID	Model Name	3M PI Part Number	Description	3M ID
16EZA	4814901	Standard Small Holder	70020233048	16EZB	6123501	Standard Large Holder	70020218551
16EZA	4814902	Small Holder with Electropolish Finish	70020253889	16EZB	6123502	Large Holder with Mechanical Polish Finish	70020252899
16EZA	4815501	Modified Small Holder Suitable for Autoclaving	70020236512				

* Based on testing with 1M NaOH and 5% NaClO (Bleach). See Chemical Compatibility Guide (70-0202-2023-5/LITPHG03) for more information.

Important Notice

3M PURIFICATION INC. MAKES NO REPRESENTATIONS OR WARRANTIES, EITHER EXPRESS OR IMPLIED INCLUDING WITHOUT LIMITATION ANY WARRANTIES OF MERCHANTABILITY, FITNESS FOR A PARTICULAR PURPOSE OR OF ANY OTHER NATURE HEREUNDER WITH RESPECT TO INFORMATION OR THE PRODUCT TO WHICH INFORMATION REFERS.

A variety of factors can affect the performance of a 3M Purification Inc. product in a particular application, some of which are uniquely within your knowledge and control. It is your responsibility to determine if additional testing or information is required and if the 3M Purification Inc. product is fit for a particular purpose and suitable in your specific application.

INFORMATION IS SUPPLIED UPON THE CONDITION THAT THE PERSONS RECEIVING THE SAME WILL MAKE THEIR OWN DETERMINATION AS TO ITS SUITABILITY FOR THEIR USE. IN NO EVENT WILL 3M PURIFICATION INC. BE RESPONSIBLE FOR DAMAGES OF ANY NATURE WHATSOEVER RESULTING FROM THE USE OF OR RELIANCE UPON INFORMATION.

Limitation of Liability

3M PURIFICATION INC. WILL NOT BE LIABLE FOR ANY LOSS OR DAMAGE ARISING FROM THIS 3M PURIFICATION INC. PRODUCT, WHETHER DIRECT, INDIRECT, SPECIAL, INCIDENTAL, OR CONSEQUENTIAL, REGARDLESS OF LEGAL THEORY ARRESTED, INCLUDING WARRANTY, CONTRACT, NEGLIGENCE OR STRICT LIABILITY. SOME STATES AND COUNTRIES DO NOT ALLOW THE EXCLUSION OF INCIDENTAL OR CONSEQUENTIAL DAMAGE, SO THE ABOVE LIMITATION OR EXCLUSION MAY NOT APPLY TO YOU.



Innovative Filtration

Fast. Easy. Clean.

Your Local Distributor:



3M Purification Inc.
400 Research Parkway
Meriden, CT 06450
U.S.A.
(800) 243-6894
(203) 237-5541
Fax (203) 630-4530
www.3Mpurification.com

3M is a trademark of 3M Company.
Zeta Plus is a trademark of
3M Company used under license.
© 3M 2010. All rights reserved.
70-0202-3967-2
REV 1210