

Zeta Plus™ Activated Carbon

Cartridges & Capsules

Zeta Plus™ Filter Medium: The efficient way to decolorize your process liquids

Zeta Plus filter medium incorporates the latest activated carbon technology to decolorize and remove contaminants from your process streams. Zeta Plus filter media can be used in any application where bulk activated carbon is used.

Zeta Plus Principle

The activated carbon is made into Zeta Plus filter media with the addition of cellulose fibers and a positively charged resin. This eliminates the use of bulk carbon that causes dust-related issues especially for operators. Figure 1 shows activated carbon and Zeta Plus filter medium.

3M Purification incorporates five standard types of activated carbon to cover a broad range of applications. These have been specifically selected for their properties to meet industry requirements. Zeta Plus filter media are also available in different porosities so that solutions with different viscosities can be processed.

Flow Rate Influence

Adsorption of molecules by activated carbon relies on Vander Waals' forces. As those interactions are of short range, contact time between the solution and the filter media is critical. Graph 1 shows the influence of the flux on the adsorption capacity of the filter media. It shows that when the flux increases the adsorption capacity of Zeta Plus filter media decreases.

Features & Benefits

Immobilized carbon in a cellulose-resin binder matrix.

- Eliminates the handling of bulk powdered carbon, eliminates equipment and solvent contamination with carbon dust and improves worker safety.

Variety of carbon types available.

- Provides a customized solution that enables maximum process economy, fewer unit operations and less re-work of off spec material.

Totally enclosed, sanitary design filter cartridge housing.

- Significantly reduces time required for cleaning between batches and reduces operator exposure to harmful solvent fumes.

Easy to install filter cartridges.

- Easy to use, reduces labor costs, positive sealing mechanism.

Full range of cartridge and capsule configurations.

- Full range of scalable configurations from bench top to production.

FDA Drug Master File, Biological Safety, Regulatory Support File & Certificate of Quality.

- Eases validation and regulatory submissions from bench top to production.



Applications

- | | |
|----------------------------|--|
| Pharmaceuticals | <ul style="list-style-type: none">▪ Decolorization in production of vitamins, antibodies, dextrose, & gelatin enzymes▪ Parenterals▪ Blood fractionation▪ Catalyst removal from API |
| Chemicals | <ul style="list-style-type: none">▪ Catalyst removal▪ Bulk pharmaceutical actives & intermediates▪ Decolorization of solvents▪ Decolorization of fine chemicals▪ Removal of organic contaminants |
| Cosmetics | <ul style="list-style-type: none">▪ Alcohol deodorization▪ Decolorization of perfumes |
| Food & Beverage | <ul style="list-style-type: none">▪ Removal of trace organic contaminants from gelatin, pectin, juices, oils▪ Decolorization of wine & cider▪ Decolorization of sugar▪ Spirit purification▪ Fatty haze removal |

Figure 1: Zeta Plus Filter Medium

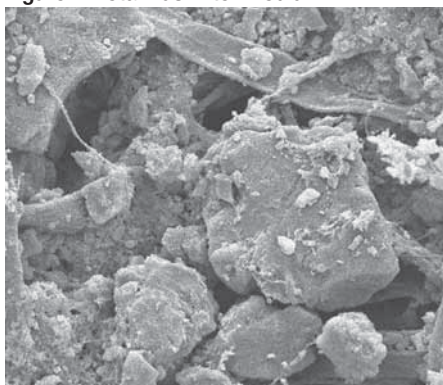

Graph 1: Adsorption Capacity at Various Flow Rates

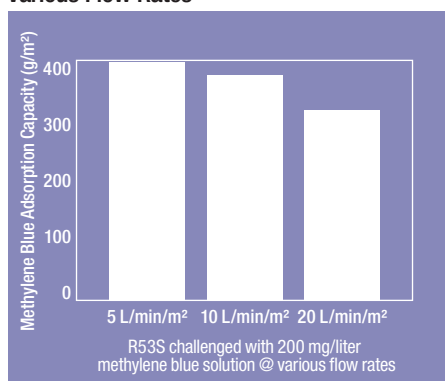

Graph 2: Grade Selection

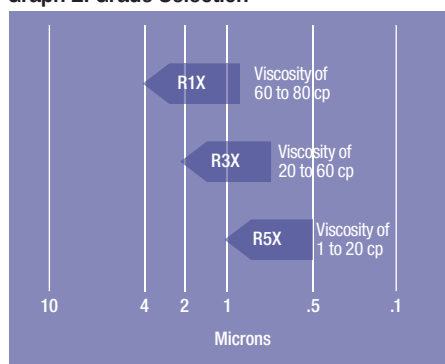

Evaluation and Scaling-up

3M Purification offers a range of Zeta Plus™ products for laboratory-scale filtration, for process development scale-up work, and for small lot production runs all the way to full scale.

Zeta Plus BC25, 1000 and 2000 disposable devices have surface areas of 25 cm² through to 1700 cm² enabling development to scale-up. In addition Zeta Plus discs (47 mm and 90 mm) are available.

Zeta Plus filtration is scaled up using a fixed value of filter flux (fluid flow rate per effective filtration area). Zeta Plus filter media should be evaluated initially at a recommended flux of 3 L/min/m² (0.07 gpm/ft²). However, there are some successful applications where flux is much higher than this recommended value, while maintaining high adsorption efficiency.

Grades of Zeta Plus Filter Media

Zeta Plus filter media are available in different porosity ratings in order to deal with products of different viscosity. Graph 2 can be used as a guide for optimum filter selection.

Cartridge Construction

Pre-tensioned cartridge construction, utilizing 316 stainless steel, ensures integrity in severe environments including *in-situ* steam sterilization and hot water sanitation. The unique edge seal design provides durable cell construction that maintains its integrity even under the most demanding process conditions.

Quality and Reliability

Zeta Plus filters are manufactured in accordance with an ISO 9001:2008 Registered Quality Management System. All materials of construction are 21 CFR compliant and cartridge and capsule filter components have been tested in accordance with United States Pharmacopoeia (USP) Class VI Biological Reactivity tests. All Zeta Plus cartridge and capsule filters are shipped with a Certificate of Quality affirming compliance with rigid manufacturing quality specifications. Supporting Drug Master File (DMF) documentation is on file with the United States Food and Drug Administration (FDA). A complete Zeta Plus Regulatory Support File is available upon request (70-0201-8830-9).

Zeta Plus BC Capsule Filters

Zeta Plus filter media is also available in BC Capsules, a range of completely encapsulated disposable depth filter assemblies for small volume biological, bioprocess, and pharmaceutical applications. BC units are available in three sizes (see ordering guide) to offer a high degree of application flexibility.

Extractables & Pyrogenicity

Inorganic and organic extractable testing was performed on Zeta Plus filter media with a variety of fluids. The following table lists typical level of metal extractables. More information on extractables and pyrogenicity is provided in the Zeta Plus Regulatory Support File (70-0201-8830-9).

Table 1: Recommended Operating Parameters

Maximum Operating Temperature	BC25 Capsules: 40°C (104°F) BC1000/2000 Series Capsules: 60°C (140°F) Cartridge: 80°C (176°F)
Maximum Differential Pressure	BC25 Capsules: 2.4 bar (35 psid) BC1000/2000 Capsules: 2.4 bar (35 psid) Cartridge: 2.4 bar (35 psid)
Recommended Rinse Volume	50 l/m ² of medium (1.25 gal/ft ²)
Recommended Flow Rate	3 liters/minute/m ² of medium (0.07 gpm/ ft ²)
Steam Sterilization	Cartridge: 1 cycle at 121°C (250°F) for 30 min. BC: Autoclave only

*Available on request, contact 3M Purification for additional information.

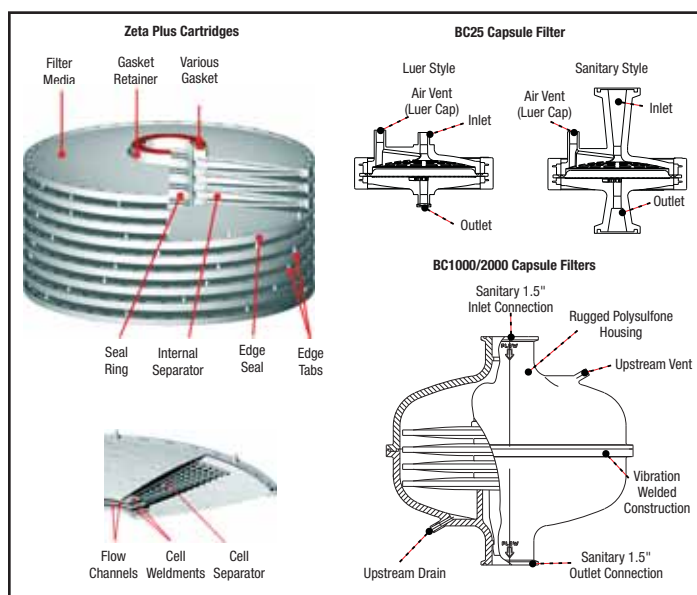

Table 2: Extractables of Metal (ppm)

Zeta Plus Type	Al	Ca	Fe	Mg	K	Si	Na
R51S	0.005	0.355	0.016	0.023	0.048	0.033	0.069
R52S	<0.005	0.470	0.005	0.070	0.083	0.160	0.510
R53S	<0.005	0.240	0.010	0.015	0.033	0.023	0.062
R54S	<0.005	0.190	0.009	0.035	0.053	0.029	1.218
R55S	0.026	0.190	0.022	0.022	0.056	0.034	0.415

Zeta Plus SP is tested for pyrogenicity by the LAL clot test. The acceptance criteria is < 0.50 EU/ml.

Table 3: Applications of Zeta Plus Activated Carbon

Application	Recommended Grade
Antibiotic Decolorization: Capromycin, Penicillin V, Cefazolin	R33S, R53S, R35S, R55S
Endotoxin removal	R53S
Removal of detergent	R32S, R52S
Removal of precipitation agent	R33S, R53S
Vaccine purification	R33S, R53S
Catalyst removal	R53S, R54S
Solvent decolorization (acetone)	R31S, R51S
Removal of trace organic contaminants from active compounds	R31S, R51S, R34S, R54S
Removal of trace organic contaminants from X-Ray contrast media	R33S, R53S
Blood fractionation: albumin decolorization, pKa reduction, biliverdine removal	R33S, R53S
Trace contaminant removal from Vodka, Whisky and Gin	R31S, R51S
Silicon oil decolorization	R11S, R14S

Zeta Plus™ Activated Carbon Cartridge Ordering Guide

Zeta Plus BC Capsule Filters

Capsule Designation	Nominal Filter Area	Packaging**	Grade	Quality Grade
BC	0025 - 3.9 in ² (25 cm ²)	L - (Luer) S - (Sanitary)	R11S, R12S, R13S, R14S, R15S, R31S, R32S, R33S, R34S, R35S, R51S, R52S, R53S, R54S, R55S	P - Pharmaceutical
	1000 - Capsule 0.7 ft ² (650 cm ²) 2000 - Capsule 1.4 ft ² (1300 cm ²)	A - Single Filter B - 3 Filter Pack		

Standard Zeta Plus Cartridges

Base Cartridge Number	Gasket Material	Grade	Quality Grade
45109 - 8" x 7" cell DOE* - 2.5 ft ² (0.23 m ²) media surface area	11 - Nitrile 13 - Fluorocarbon 14 - EPR 22 - Silicone 23 - PTFE	R11S, R12S, R13S, R14S, R15S, R31S, R32S, R33S, R34S, R35S, R51S, R52S, R53S, R54S, R55S	P - Pharmaceutical
45167 - 8" x 6" cell Plug in - 2.1 ft ² (0.20 m ²) media surface area	01 - Nitrile 02 - EPR 03 - Fluorocarbon 04 - Silicone 09 - PTFE Encapsulated Fluorocarbon		
45158 - 12" x 9" cell DOE* - 9.2 ft ² (0.9 m ²) media surface area 45159 - 12" x 13" cell DOE* w/Stainless Steel Bands - 13.3 ft ² (1.2 m ²) media surface area 45809 - 12" x 13" cell DOE* w/Hastelloy® Steel Bands - 13.3 ft ² (1.2 m ²) media surface area	01 - Nitrile 03 - Fluorocarbon 04 - EPR 06 - Silicone 07 - PTFE		

Base	Configuration	O-Ring Material	Packaging	Grade	Quality Grade
Z8FA2 - 8" Plug-in with 2 cells - 0.7 ft ² (650 m ²) media surface area Z8FA4 - 8" Plug-in with 4 cells - 1.4 ft ² (1300 m ²) media surface area	NP	A - Silicone B - Fluorocarbon C - EPR D - Nitrile E - PTFE Encapsulated Fluorocarbon	2	R11S, R12S, R13S, R14S, R15S, R31S, R32S, R33S, R34S, R35S, R51S, R52S, R53S, R54S, R55S	P - Pharmaceutical

Base	Cartridge Design	Gasket Material	Grade	Quality Grade
C16	M - 16" x 13" cell DOE w/Stainless Steel Bands - 32.2 ft ² (3.0 m ²) media surface area	A - Silicone B - Fluorocarbon C - Ethylene Propylene (EPDM) D - Nitrile E - PTFE	R11S, R12S, R13S, R14S, R15S, R31S, R32S, R33S, R34S, R35S, R51S, R52S, R53S, R54S, R55S	P - Pharmaceutical
	R - 16" x 13" cell DOE w/Hastelloy® Steel Bands - 32.2 ft ² (3.0 m ²) media surface area			

*Double Open End. **Other Gasket Materials are available. For sheets and discs contact your local 3M Purification distributor.

Important Notice: The information described in this literature is accurate to the best of our knowledge. A variety of factors, however, can affect the performance of the Product(s) in a particular application, some of which are uniquely within your knowledge and control. **INFORMATION IS SUPPLIED UPON THE CONDITION THAT THE PERSONS RECEIVING THE SAME WILL MAKE THEIR OWN DETERMINATION AS TO ITS SUITABILITY FOR THEIR USE. IN NO EVENT WILL 3M PURIFICATION INC. BE RESPONSIBLE FOR DAMAGES OF ANY NATURE WHATSOEVER RESULTING FROM THE USE OF OR RELIANCE UPON INFORMATION.**

It is your responsibility to determine if additional testing or information is required and if this product is fit for a particular purpose and suitable in your specific application.

3M PURIFICATION INC. MAKES NO REPRESENTATIONS OR WARRANTIES, EITHER EXPRESS OR IMPLIED INCLUDING WITHOUT LIMITATION ANY WARRANTIES OF MERCHANTABILITY, FITNESS FOR A PARTICULAR PURPOSE OR OF ANY OTHER NATURE HEREUNDER WITH RESPECT TO INFORMATION OR THE PRODUCT TO WHICH INFORMATION REFERS

Limitation of Liability: 3M Purification Inc. will not be liable for any loss or damage arising from the use of the Product(s), whether direct, indirect, special, incidental, or consequential, regardless of the legal theory asserted, including warranty, contract, negligence or strict liability. Some states do not allow the exclusion or limitation of incidental or consequential damages, so the above limitation may not apply to you.



3M Purification Inc.

400 Research Parkway
Meriden, CT 06450
U.S.A.
(800) 243-6894
(203) 237-5541
Fax (203) 630-4530
www.3mpurification.com

3M is a trademark of 3M Company.
Zeta Plus is a trademark of 3M Company used under license.
All other trademarks are the property of their respective owners.
© 2011 3M Company. All rights reserved.
70-0201-8733-5
REV 0411b

Your Local 3M Purification Distributor: